

# My Balsa & Glass Workshop

## My Workshop Lantern Project Build Description

Final Version as of 10 December 2024

Here is a simple Stained Glass project that I currently have in progress. This project will end up becoming an outdoor hanging lantern that will hang above the entryway of **“My Balsa and Glass Workshop.”** I'm going to go through the basic steps for any Stained Glass project using the copper foil, or “Tiffany” method, but only this time, I promise.

The left image below I found on the web, which I then used to draw my pattern (center image) with a simple 2-D CAD program called “Back to the Drawing Board” and available @ <https://drawingboardapp.com/>. Using a pair of stained glass “foil” pattern shears that will cut out a space between the individual pattern pieces for application of copper foil, cut out each piece in the pattern.

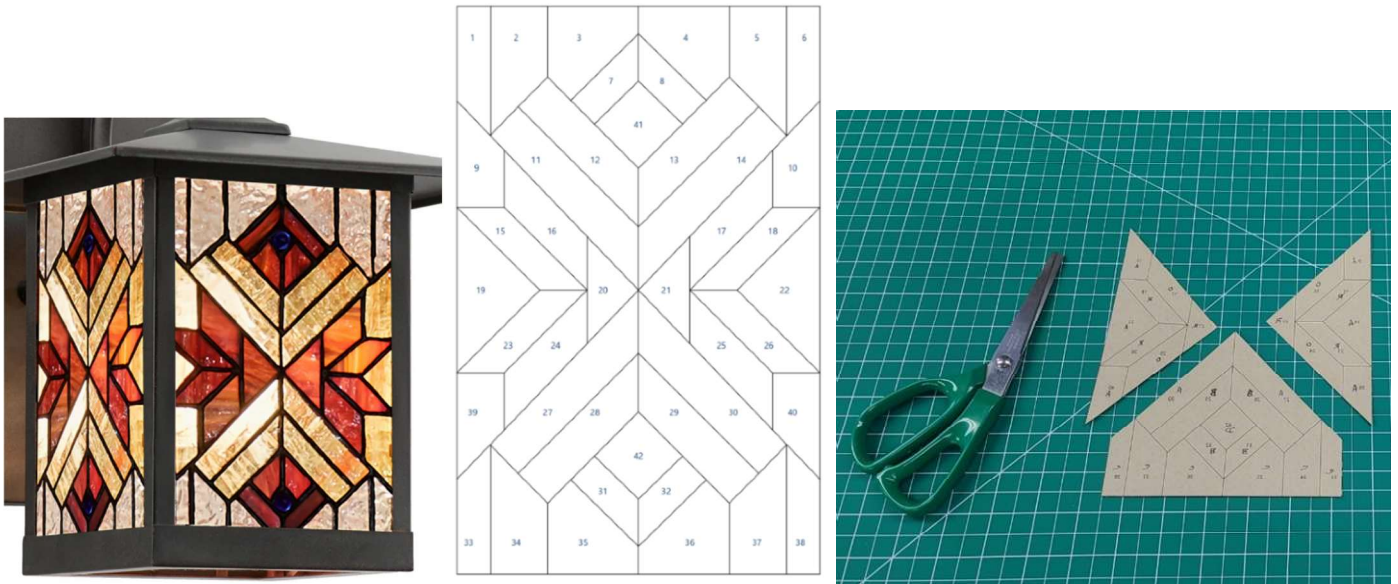

As shown in the left image below, select the colors of glass you plan to use for your panel and set them in a glass holder on the workbench versus always trying to find the glass you need in the larger storage racks. The right image is your cutting station where you trace the pattern pieces on the stained glass using a sharp pointed marker pen, and then cut each piece using good glass cutter and glass breaker pliers. **Note** – For any textured glass, like the clear rippled glass I'm using in my panels, trace and cut the pattern on the smooth side of the glass sheet. Remember to turn the pattern over when tracing on the back side of the glass.



Now move to the grinder station (top image below) where you grind each piece using a tabletop wet grinder until you just remove the pattern lines. As you can tell, *this old man needs lots of light on the grinder wheel to be able to see the pattern lines.* At the panel assembly station check the fit against the pattern and grind more if needed.



Once you are good with the fit of a glass piece, move over to the foiling station (see below) to apply copper foil to the edges on each piece of stained glass, and then place them back over the pattern at your assembly area (image above). **Note** – I



normally use 3/16" 1.25 mil copper backed foil for most of my projects. Also, while there are many different types of "table foiling machines" for sale out there, and I've tried them, I found myself coming back to using just my fingers and a careful eye to properly align the foil to produce the same width foil lines on each side of a glass piece. I just found this method faster especially when working with small glass pieces. The black hard rubber mat in the image below is an excellent surface to use for foiling and remember to "burnish" all the foiled edges. I use a hardwood dowel tapered on one end (laying on the mat) to do my copper foil burnishing.



The left image below is the first panel ready for application of "Classic 100 Gel Flux" and soldering. Note - I normally use 60/40 solder (60% tin - 40% lead) on most of my projects. The right image is a completed 5.75" x 9", 38 piece lantern side panel sitting on a small LED light table.





The image below is the Stained Glass side of **“My Balsa and Glass Workshop,”** where you can see how I have all the various stations positioned arranged on an 8’ workbench, and any required tools and materials along the back pegboard wall. This setup works great for me, and you can have something similar in a small spare room of your home.



With all four side panels finished, I moved on to make the lantern top. As I have done for my earlier lanterns, I used black glass which is cut large enough to slightly hang outside of the four side panels.

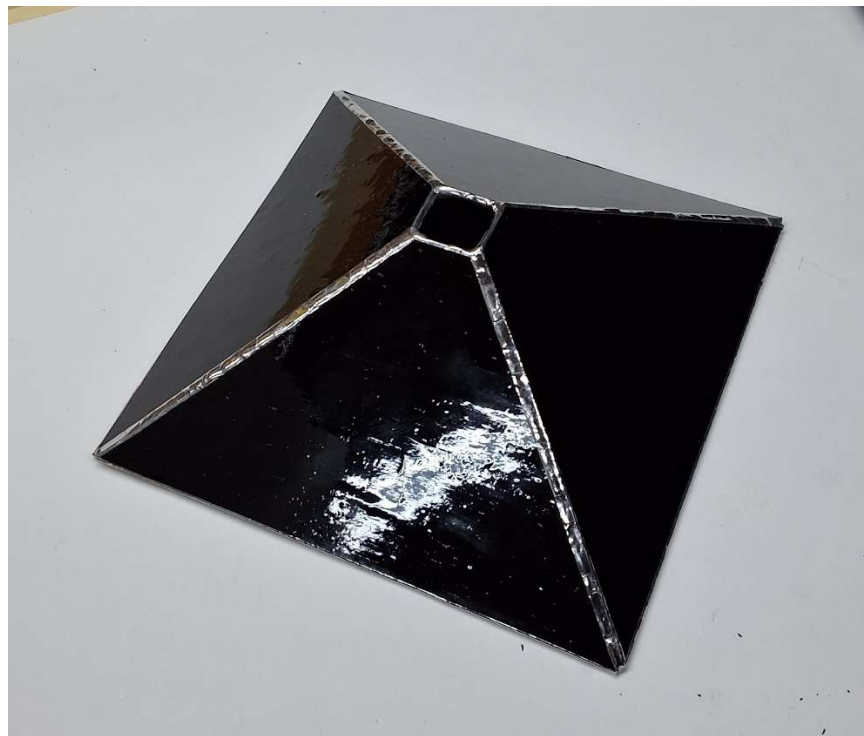

In preparation for soldering the lantern sides together, I decided to build a small wooden fixture (left image below) that would not only hold two sides at 90 degrees to each other, but also places the seam level to the workbench which helps greatly

at keeping the hot solder in place versus running all over the place. *I should have made this fixture a long time ago.* **Note** - Before you solder the two panels together, double check that each panel is placed with the finished side facing outward. This may seem silly to say, but I have made the mistake of soldering a panel in an earlier lantern that had the bevels facing inward.

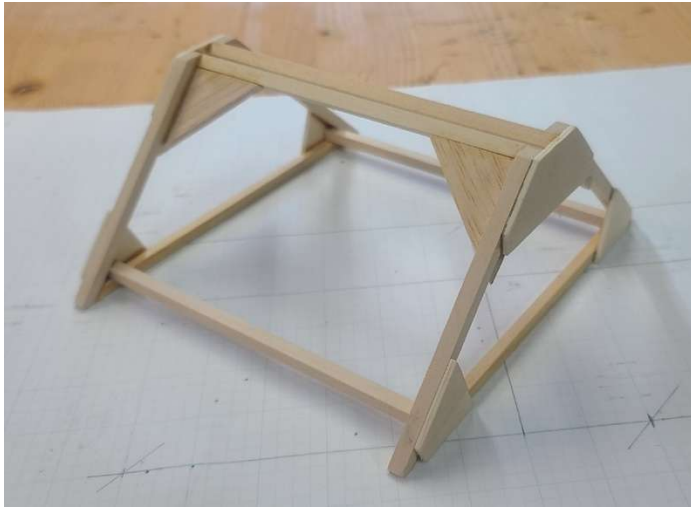

The image below shows the lantern now ready for final assembly using the square brass lamp shade cap, and brass four prong spider laying on the table. This lantern will be lit using a single 12 volt LED lamp and controlled with an outdoor lighting transformer.





I used black patina to color the solder joints on the black top, and then assembled all the lamp hardware and wiring for the LED light. With everything assembled, I finished the project by mounting the transformer on the wall inside my workshop, and then the lantern outside above the entryway. The final image below shows the finished lamp outside in a light misty rain. I think it turned out real nice and it will look great at night.



Don't forget, all the images in this build description are available for you to view in greater detail and in a larger size on my website @: [https://balsaandglass.com/SG\\_Builds.html#ShopLtn](https://balsaandglass.com/SG_Builds.html#ShopLtn) .